

VOICE SYNTHESISER TYPE VS1

INTRODUCTION

The VS1 Voice Synthesiser System comprises of a Controller Interface Module (fitted in the lift controller, which has integral control with the TC3 Digital Indicator range), and a Voice Synthesiser fitted on the lift car or landings.

The Controller Interface Module will support upto 64 digital indicator or Voice Synthesiser units. The Voice Synthesiser Unit can announce upto 32 floor references (which are site programmable within the standard voice library constraints), direction status, door status, and 3 messages.

Voice Synthesiser Unit Features

Intelligent selection of 32 floor announcements, direction status, door status, and 3 message announcements.

Uses latest developments of circuit integration together with surface mount manufacturing techniques to give an indicator footprint of 70mm. x 65mm. and 40mm deep.

Utilises CAN communications to reduce site wiring and ease installation (2 wires for power and 2 wires for communications).

The Output Audio is via a 8 ohm speaker at 1 watt.

Controller Interface Unit Features

Incorporates Liquid Crystal Display to monitor and program the Digital Indicator and Voice Synthesiser operation.

Floor Identities are site programmable into NVRAM with no special equipment required provided the floor announcements are within the standard announcement library.

Inputs are opto-isolated for 24Vdc operation and include :-

Binary position inputs PA, PB, PC, PD, PE, PF for upto 32 floors.

SX input for Speech Position Data Announcement control

IU, ID,HL inputs for Hall Lantern Announcement control.

DC, DO inputs for door open and close announcements.

OS, OL, FC for messages.

Note: A decimal to binary encoder unit is available as an optional chargeable extra to help controller position data interfacing.

VOICE SYNTHESISER TYPE VS1

VOICE SYTHESISER CONNECTION DIAGRAM

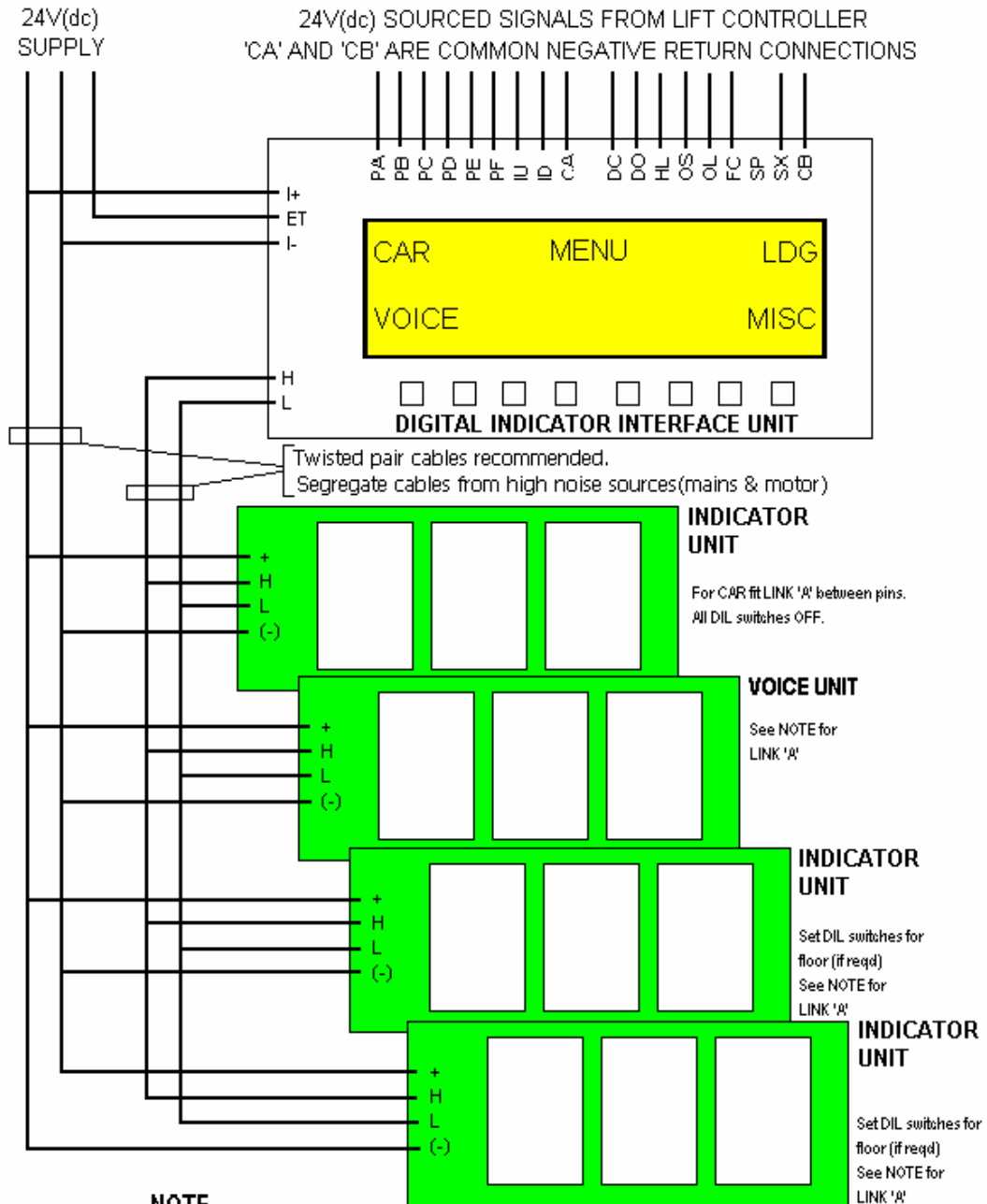

NOTE

LINK 'A' is supplied connected on one pin only for all Indicator units.
LINK 'A' must be fitted between both pins for last unit in communications run only (car & landing furthest from controller). Other units have LINK 'A' on one pin only.

- PA,PB,PC,PD,PE,PF** _____ POSITION INPUTS (BINARY)
IU,ID,HL _____ HALL LANTERN CONTROL INPUTS
DC,DC _____ DOOR OPEN / CLOSE CONTROL INPUTS
OL,OS,FC _____ MESSAGE INPUTS (overload, out of service, fire)
SX _____ SPEECH CONTROL (silence position statement)

VOICE SYNTHESISER TYPE VS1

INTERFACE UNIT CONTROLS

Following power initialisation the system is set to the 'main menu' operation to give a display as follows :-

CAR	MENU	LDG
VOICE		MISC

PUSH BUTTON FUNCTIONS

<i>Left Arrow</i> _____	Shifts cursor one field to left
<i>Right Arrow</i> _____	Shifts cursor one field to right
<i>Up Arrow</i> _____	Shifts cursor up one line
<i>Down Arrow</i> _____	Shifts cursor down one line
<i>Menu</i> _____	Returns display to Main Menu Screen
<i>RTN</i> _____	Selects / terminates function or instruction
<i>SET</i> _____	Selects Position Floor Reference Setup operation
<i>SAVE</i> _____	Selects saving of Floor Reference Data

To show the data displayed by the voice synthesiser push cursor left once, then cursor down one, then push return once to give display as follows :-

P=01	^VOICE^	D=SB
-----CAR OVERLOADED-----		

This shows the data regarding the Voice Synthesiser as having an absolute position of floor '01' (bottom), an announced position of 'SB', an Up direction and hall lantern operational, and a 'Car Overloaded' message displayed.

To return to the 'Main Menu' press 'Menu' push.

VOICE SYNTHESISER TYPE VS1

SETTING THE FLOOR REFERENCES

The Floor References corresponding to the absolute lift position (floor 1 as bottom) may be programmed on site with no special equipment required. To enter the position reference setup operation press 'SET' push to give the following display :-

P=01	D=SB
SET DISPLAY DATA	

Use the UP or DOWN ARROW to increase or decrease the absolute position to the required floor.

Push the RIGHT ARROW to shift to the displayed position (left hand character).

Use the UP or DOWN arrow to set the character to +, -, space, or any numeric or alphabetic character (push may be held down to scroll).

Push the RIGHT ARROW to shift to the displayed position (right hand character).

Use the UP or DOWN arrow to set the character.

Press SAVE push to save the data.

The display will respond by showing 'save ?' on the top line centre.

Press SAVE push again to confirm.

The display will respond by showing 'saving' on the top line centre.

After a few seconds the display will show 'saved !' on the top line centre.

The data for the set entry is now set in NVRAM (held even if the supply is switched off).

After a few further seconds the display will return to the set display data screen shown above.

The procedure may be repeated for further floor entries or the MENU push may be pressed to return to the basic MENU screen.

If in doubt at any time press the MENU button to recover back to the MENU screen.

VOICE SYNTHESISER TYPE VS1

VOICE SYNTHESISER OPERATION

A CAN link is used to transfer data between the Interface Unit and the Voice Synthesiser. LED indicators are illuminated on the Voice Synthesiser PCB to show :-

- S _____ 5Vdc power supply monitor.
- R _____ Receive data monitor for CAN link (raw CAN data).
- C _____ Communications confirmation monitor for CAN Data.
- B _____ Busy signal illuminated when the speech controller is engaged in sending a voice statement.

'C' indicator shows the data has been received correct following integrity checks.

During NORMAL operation led status should be :-

- S _____ illuminated constantly
- R _____ pulsing at approximately 0.25 second intervals
- C _____ pulsing at approximately 1 second intervals.
- B _____ pulses while an announcement is spoken.

Although the CAN link is reasonably noise immune, the unit wiring should be segregated from sources of high electrical noise such as heavy mains or motor wiring. Initial recommendations are to use twisted pairs for communications and supply wires, or screened cable where noise problems are experienced.

DIL SWITCH SETTINGS

A 4 way dil switch is fitted on the Voice Synthesiser PCB to set the type of usage.

- DIL switch 1 _____ OFF = inhibit gong up and down chime statements
ON = enable gong chime operation
- DIL switch 2 _____ OFF = inhibit going up and going down statements
ON = enable going up and going down statements
- DIL switch 3 _____ OFF = enable doors opening and closing statements
ON = enable please mind the doors statement
- DIL switch 4 _____ OFF = enable silence control
ON = disable silence operation

POWER SUPPLY REQUIREMENTS

Voice Unit _____ 24Vdc smoothed at 0.25A

Interface Unit _____ 24Vdc smoothed at 0.5A

STANDARD VOICE ANNOUNCEMENT LIBRARY

SB	Sub Basement Floor	0, 1 to 32	Numeric Floor
LB	Lower Basement Floor	-1 to -5	Minus Numeric Floor
UB	Upper Basement Floor	CP	Car Park Floor
B	Basement Floor	L	Lobby Floor
LG	Lower Ground Floor	MZ	Mezzanine Floor
UG	Upper Ground Floor	PH	Penthouse Floor
G	Ground Floor	R	Reception Floor

VOICE SYNTHESISER TYPE VS1

VOICE SYTHESISER CONTROLS

Position Control

Position statements are announced once only each time the position changes.

The 'SX' input may be energised to inhibit position statements (possibly while travelling between floors via a normally open HSR contact).

Position statements will only be announced providing the Position Indicator Display character has a match within the Voice Synthesiser Statement Library. Special contract specific Voice Libraries are available on request at extra cost.

Door Control

The unit will either announce 'doors opening / closing' or 'please mind the doors' dependent upon DIL Switch settings.

'Please mind the doors' statement is only made on closing.

Since continual repetition of door control statements may be considered a nuisance when used in residential environments, door statements may be automatically silenced if more than 25 door statements are made at a constant floor position. The voice function will return to normal if a new position statement is invoked, or no door statement requests are made for 2 minutes. This automatic silence function can be inhibited via DIL switch operation, since under certain circumstances it may be considered better to always give door announcements (for the sake of blind passengers). Only 'door' statements are affected by silence control

Direction Control

The unit will announce either 'going up / down' or one gong for up / two gongs for down, selectable under DIL switch operation. Direction statements will commence under control of the 'HL' input on the Interface Unit, and the 'doors opening' statement. Primarily 'direction' statements are enabled only after the 'door open' statement is given at a floor. Once enabled all direction statements are given until they are inhibited via the change of the lift position. In order to register a direction statement the 'Interface Unit' must receive an 'HL' input together with an 'IU or ID' input.

Message Control

Standard Messages are available for Fire Control, Lift Out of Service, and Car Overloaded.

When a new message is invoked it is announced once only. A 'no message' signal will recycle the message announcement control.